

LAMP WARE

NEW VALUE RANGE
DEC 2017

SQUARE TRAILER LAMP

DESCRIPTION

- 100mm x 100mm
- Multivolt – 10-30V
- ABS Housing/AS lens material
- 300mm cable
- LED quantity: 10
- 5 Year warranty
- Emark certified

PART No.

RKSTL100SQMV

\$8.95
+GST

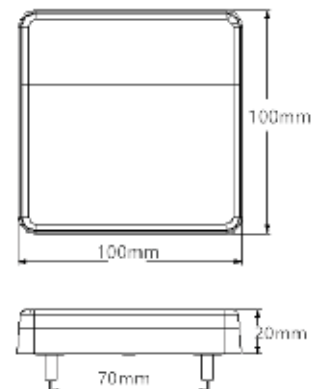

RECTANGULAR TRAILER LAMP

DESCRIPTION

- 150mm x 80mm
- Multivolt – 10-30V
- ABS Housing/AS lens material
- 300mm cable
- LED quantity: 8
- 5 Year warranty
- Emark certified

PART No.

RKSTL150RECMV

\$9.95
+GST

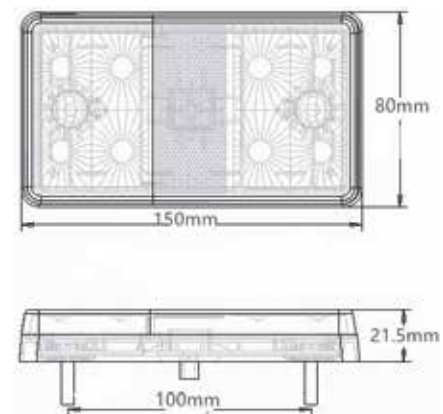

REAR COMBINATION LAMP

DESCRIPTION

- Stop/Tail/Indicator/Reverse
- 258mm x 68mm
- Multivolt – 10-30V
- ABS Housing/AS lens material
- 300mm cable
- LED quantity: 27
- 5 Year warranty
- Emark certified

PART No.

RKSTLRCMV

\$24.95
+GST

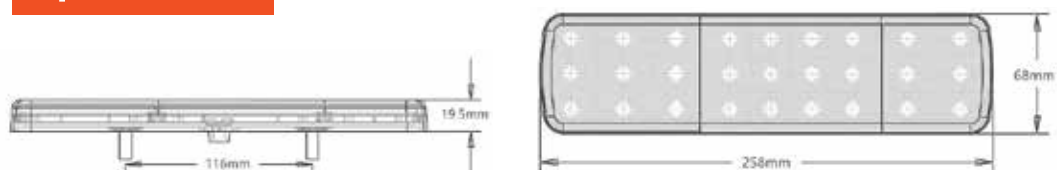

MARKER LAMPS

DESCRIPTION

- 60mmx 30mm
- 300mm cable
- Multivolt – 10-30V
- LED quantity: 4
- ABS Housing/Polycarbonate lens material
- 5 Year warranty
- ADR certification pending

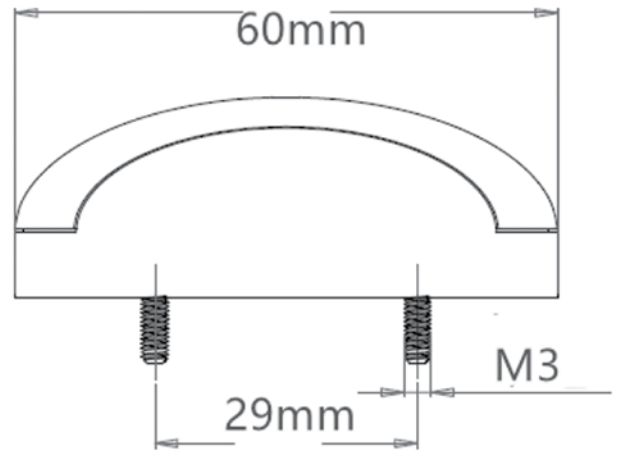
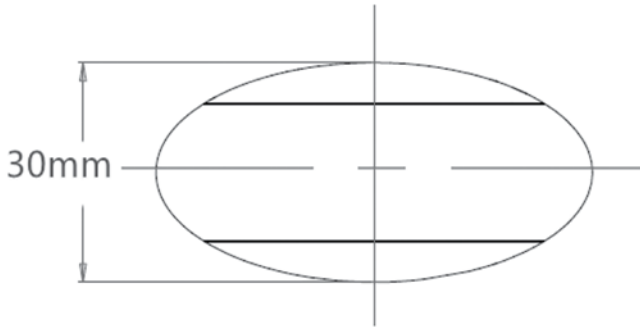

WHITE MARKER LIGHT

PART No.

RKSMLWMV

\$5.95
+GST



RED MARKER LIGHT

PART No.

RKSMLRMV

\$5.95
+GST



AMBER MARKER LIGHT

PART No.

RKSMLAMV

\$5.95
+GST



AMBER/RED MARKER LIGHT

PART No.

RKSMLARMV

\$5.95
+GST



1300 914 868
6 Jarrah Drive Braeside VIC 3195
sales@rkssales.com.au



6326 1813
5/190 Invermay Rd, Invermay 7248
rkstas@rkssales.com.au